

ict



FP-003 PLUS

PROGRAMMER

Use of Materials Limitations

International Currency Technologies Corporation (ICT) all rights reserved.

All materials contained are the copyrighted property of ICT.

All trademarks, service marks, and trade names are proprietary to ICT.

ICT reserves the right at all times to disclose or to modify any information as ICT deems necessary to satisfy any applicable law, regulation, legal process or governmental request, or to edit, refuse to post or to remove any information or materials, in whole or in part, in ICT's sole discretion.

1. General Specification :

1. Voltage : DC12V~24V ±5%
2. Current : 100mA
3. Power Consumption : 1.2W
4. Size : (Length) 105mm X (Width) 55mm X (Thickness) 24mm
5. Operating Temperature : 0°C~ 60°C
6. Storage Temperature : -20°C~70°C
7. Operating Humidity : 0% ~ 85% (RH)

Adapter Specification :

1. Model : HAPU04F2
2. Input : 100-240V~50/60Hz 0.5A

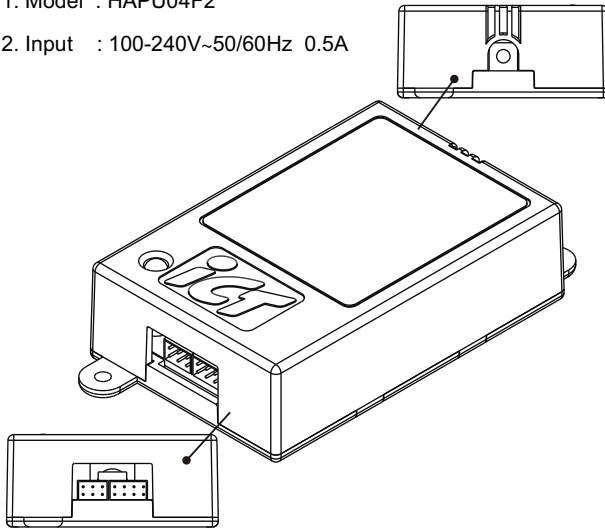

2. Indirect Downloading :

PC → BA

Step 1 : Connection

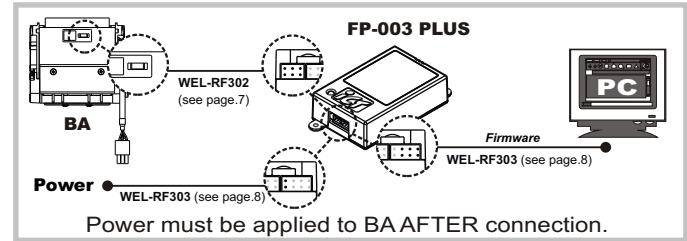

Step 2 : Download FP-003 PLUS Software

Download FP-003 PLUS Software from
<http://www.ictgroup.com.tw/> → support

Step 3 : FP-003 PLUS setting. Port COM1 OR COM2
The com port setting varies according to the connection on PC.

Step 4 : Retrieve the firmware path.

Drag the firmware(hex file)into FP-003 PLUS window.

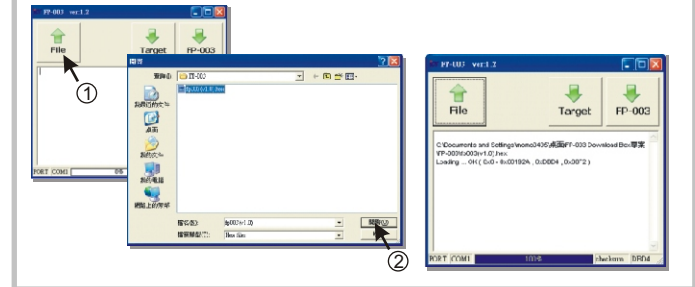

Step 5 : Download firmware to target through FP-003 PLUS.

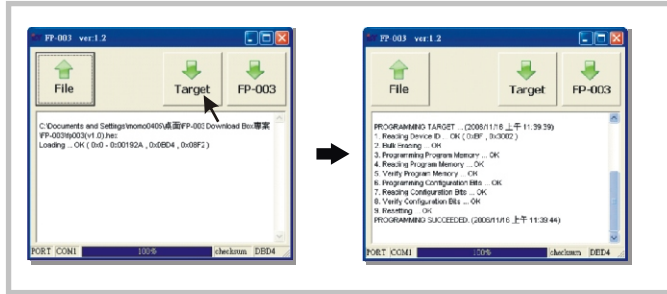

Step 6 : Download complete. Firmware is saved in BA now.

PC ➔ FP-003 PLUS

Step 1 : Connection

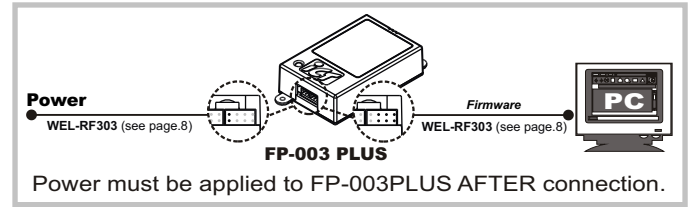

Step 2 : Download FP-003 PLUS Software

Download FP-003 PLUS Software from
<http://www.ictgroup.com.tw/> ➔ support

Step 3 : FP-003 PLUS setting. Port **COM1 OR COM2**

The com port setting varies according to the connection on PC.

Step 4 : Retrieve the firmware path.

Drag the firmware(hex file)into FP-003 PLUS window.

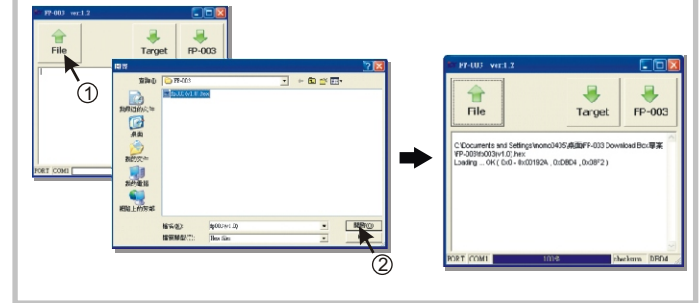

Step 5 : Start Target the firmware in FP-003 PLUS.

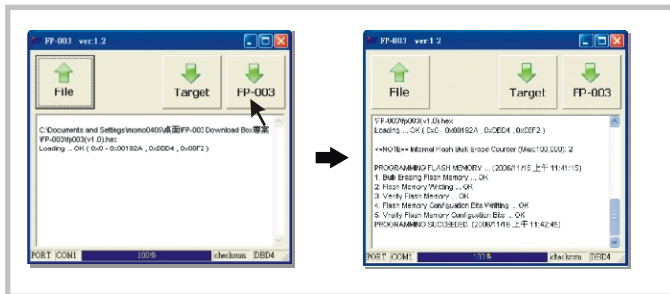

Step 6 : Download complete.
Firmware is saved in FP-003 PLUS now.

FP-003 PLUS → Target

Step 1 : Connection

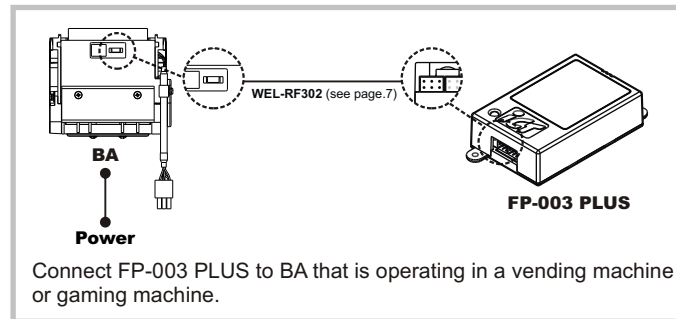

Step 2 : Start downloading a new firmware to BA.

FP003 PLUS to Target

Step1: Press and hold the button for at least 3 seconds, and wait until the faceplate LED turns to orange.

Step2: The faceplate LED will flash faster and faster as it's approaching the end of download progress.

Step3: After downloading, the faceplate LED will indicate "Green" as successful downloading or "Red" as failed downloading in 3 seconds.

Note: As downloading the firmware to BA in this **FP-003 PLUS** mode, PC Tool shows the download progress automatically.

Step 3 : Indirect downloading complete.

3. Cable :

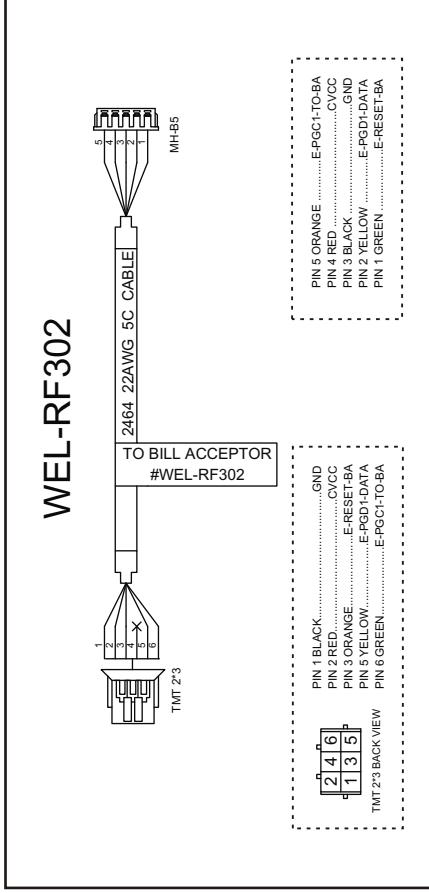

Connect FP-003 PLUS to BA.

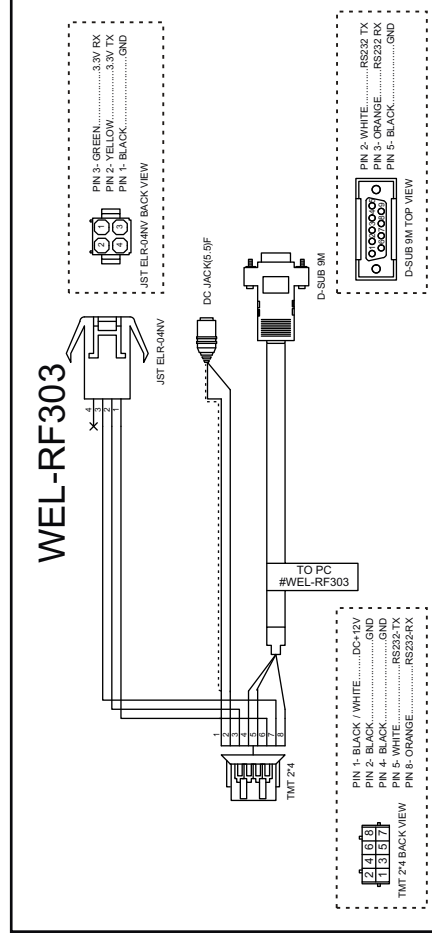

Connect FP-003 PLUS to PC and Adapter.

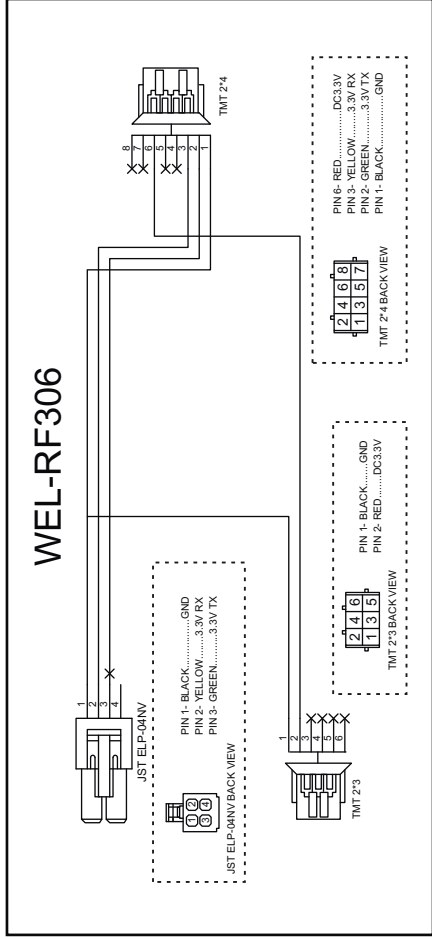

Cable for tester.

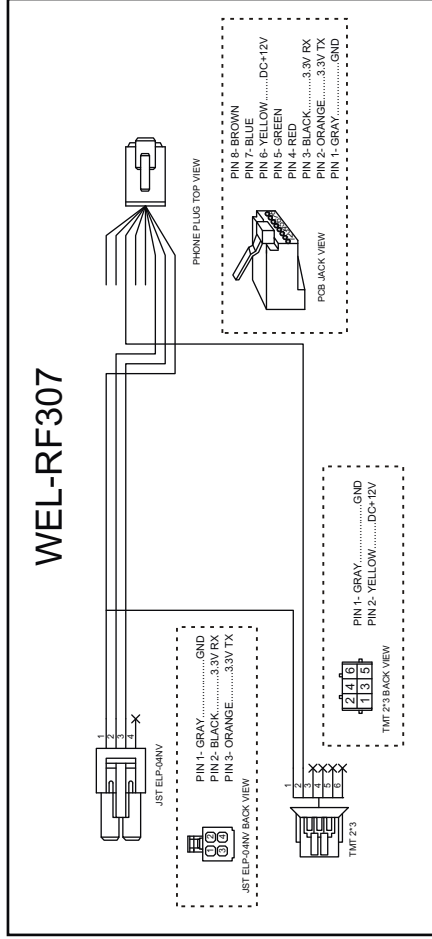

Cable for FP-003 PLUS maintenance.

ict Taiwan

International Currency Technologies Corporation

Ji-Hong Building, No 24, Alley 38, Lane 91, Nei-hu Rd., Sec. 1,
Taipei, Taiwan, R.O.C.

Tel: 886-2-2797-1238 Fax:886-2-2797-1634

sales@ictgroup.com.tw (For Sales)

rma@ictgroup.com.tw (For Customer service)

Website: www.ictgroup.com.tw